

Is your mailbox a potentially lethal weapon?

Mailboxes and mailbox supports contributed to more than 120 deaths and more than 4,600 injuries in Michigan during a recent five-year period. Why? Often because the posts were so strong or massive they did not yield when hit. Some of these accidents resulted in lawsuits against the owners.

We're concerned about this problem and hope that, by increasing awareness of it, we can avoid such death and injury in Branch County.

We hope you'll use the checklist included in this brochure to make sure your mailbox installation does not pose a hazard to the motoring public or a liability risk to you.



**MAILBOXES
AND
MAILBOX SUPPORTS**

**Location
Structure**

For more information:

- Mailbox construction and height — call your local post office.
- Mailbox supports and placement, and mailbox policy — call the Branch County Road Commission.

**Branch
County
Road Commission**

*23 E. Garfield Ave.
Coldwater, MI 49036*

All Branch County Road Commission programs, activities and services are provided equally without regard to race, color, religion, sex, national origin or handicap.

**Branch
County
Road Commission**
(517) 278-2022

Mailbox and mailbox support checklist

Location

- Mailbox is in the direction of the the carrier's route of travel, except on one-way streets.
- Mailbox height is to be determined by your mail carrier. Please contact your carrier.
- Mailbox face is between 8 inches and 12 inches from the outside edge of the road shoulder or 6 inches to 12 inches from the curb.
- Mailbox near an intersection is no closer than 100 feet from the intersecting road.

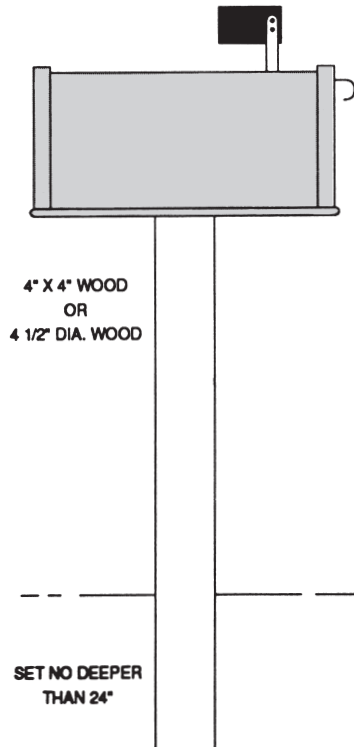

Structure

- Mailbox is of light steel, aluminum or plastic construction that meets U.S. Postal Service requirements.
- No more than two mailboxes are mounted on a single support structure.
- Mailbox post is a single 4-inch x 4-inch wood post, a 4-1/2-inch diameter wood post or a 2-inch diameter standard-strength steel pipe.
- Mailbox post is not set in concrete.
- Mailbox post is embedded no more than 2 feet into the ground.
- Mailbox post is not fitted with an anchor plate.
- Mailbox is attached to the post well enough to prevent separation if either box or post is struck by a vehicle.
- Minimum spacing between the center of grouped support posts is three-fourths the portion of the posts' height that is above the ground.

If your mailbox location or structure is not in compliance with regulations cited in the checklist, make adjustments now. Don't let your mailbox or post be an accident waiting to happen. And if you have questions, call your local post office or the Branch County Road Commission.

The Road Commission is authorized to remove

mailboxes or posts that do not meet requirements and, therefore, are hazardous to the public. The owners will be notified and given between 24 hours and 30 days to conform to standards, depending upon the degree of hazard. If unacceptable installations are not removed within the specified time, the Road Commission will handle removal at the owners' expense, as provided by Act 368, Public Acts of 1925, as amended.

